



**NOTES:**

1. R.H. SHOWN, L.H. OPPOSITE.
2. ALL DIMENSIONS ARE APPROXIMATE.

- AIR**
1. 100 PSI

**ELECTRICAL**

1. 230 VAC
2. 3 PHASE
3. CYCLE CONTROLS 60

OWNERSHIP - PROPRIETARY DATA LEGEND

THIS DOCUMENT AND THE INFORMATION CONTAINED THEREIN IS THE PROPERTY OF MARBO PACKAGING SYSTEMS, INC. RECIPIENT AGREES NOT TO USE, REPRODUCE, OR TRANSMIT IN ANY MANNER, OR TO DISCLOSE TO ANY OTHER PERSON IN WHOLE OR IN PART FOR ANY PURPOSE, WITHOUT THE EXPRESS AUTHORIZATION OF MARBO PACKAGING SYSTEMS, INC. RECIPIENT ALSO AGREES NOT TO REPRODUCE OR TRANSMIT IN ANY MANNER, OR TO DISCLOSE TO ANY OTHER PERSON IN WHOLE OR IN PART FOR ANY PURPOSE, WITHOUT THE EXPRESS AUTHORIZATION OF MARBO PACKAGING SYSTEMS, INC. AND TO PROMPTLY RETURN THIS DOCUMENT TO MARBO PACKAGING SYSTEMS, INC. UPON THE RECEIPT OF A WRITTEN REQUEST THEREFOR.

# MARBQ'S

## New Innovations

Info@marq.net • 1-800-998-4301

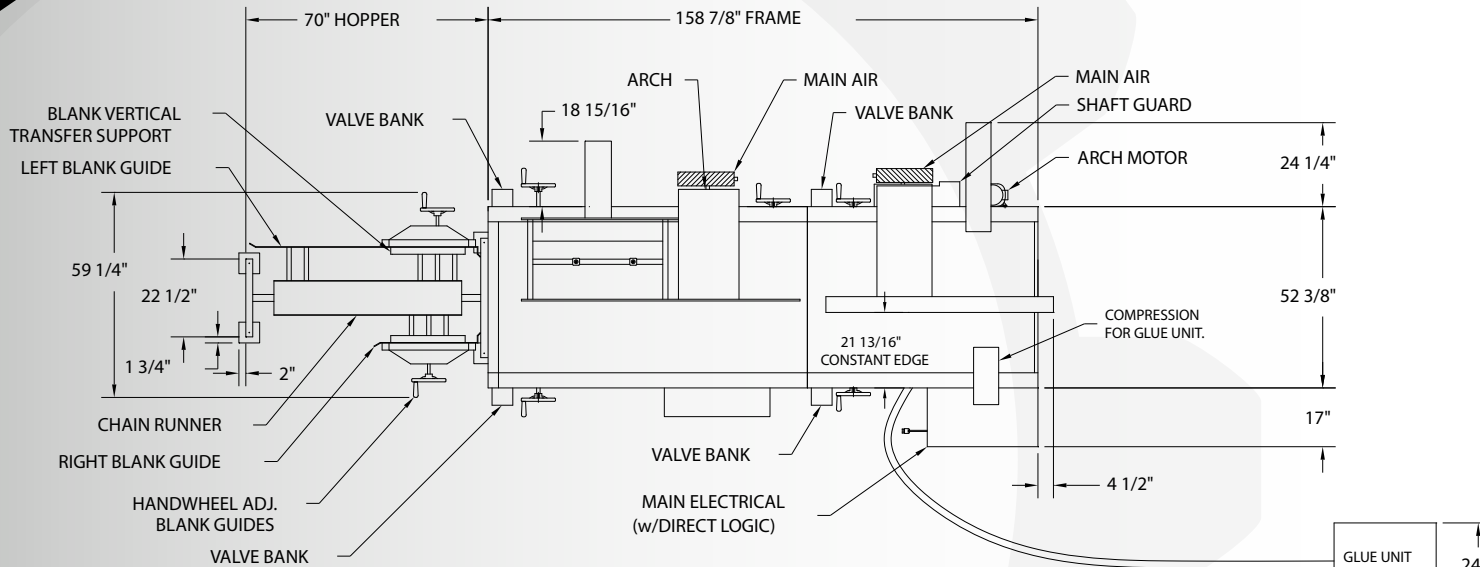

NOT ACTUAL LOCATION!  
THIS LOCATION OF GLUE UNIT  
SHOWN ONLY FOR CLARITY.  
LOCATION & DISTANCE FROM MACHINE  
IS DETERMINED BY LENGTH OF GLUE HOSE

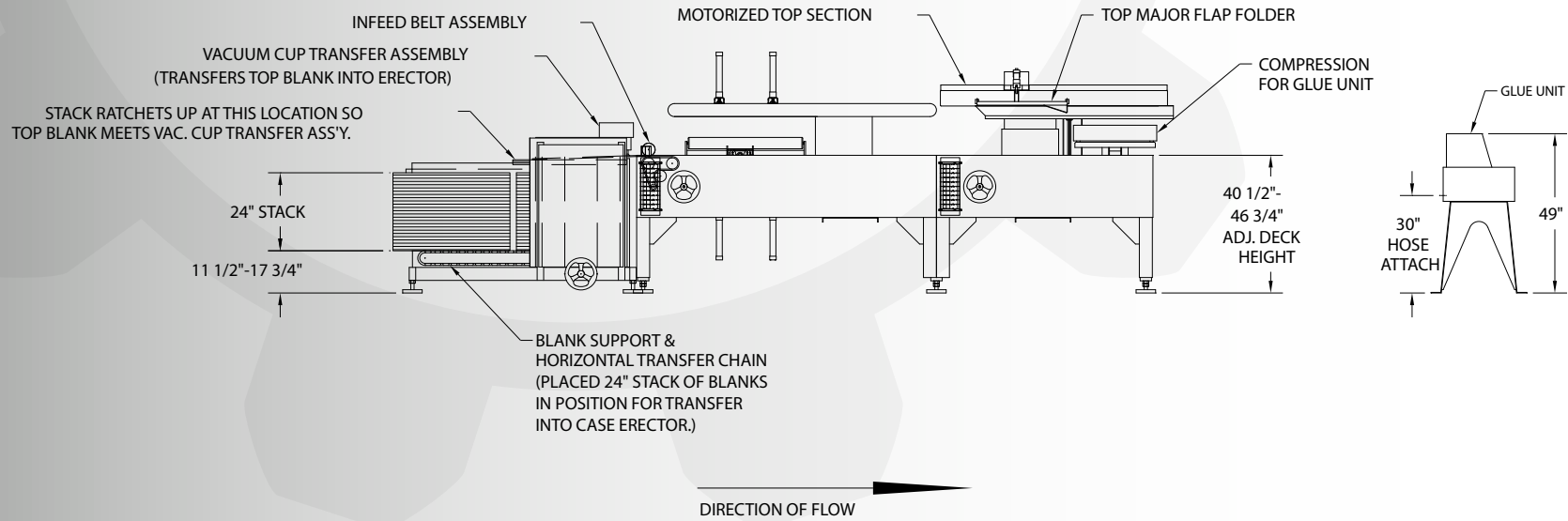

HPPE-NS-G Tablock