



NOTES:

1. R.H. SHOWN, L.H. OPPOSITE.
2. ALL DIMENSIONS ARE APPROXIMATE.
3. HSC CASES AND LIDS MUST BE OF SAME HAND CONFIGURATION REGARDLESS OF PRINTING OR LABELS.

1. 80 PSI

ELECTRICAL

1. 230 VAC
2. 3 PHASE
3. CYCLE CONTROLS 60

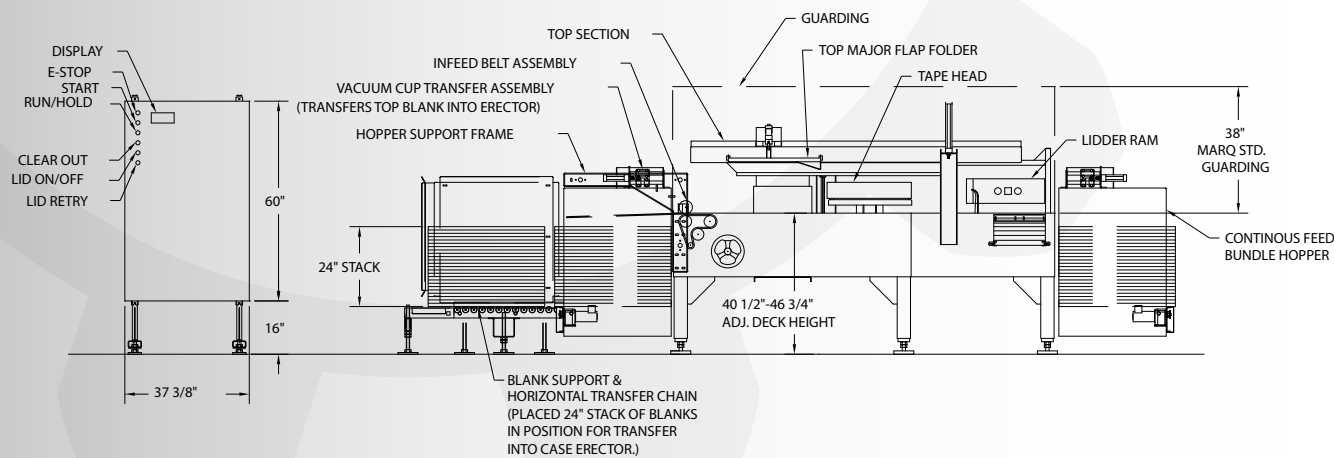
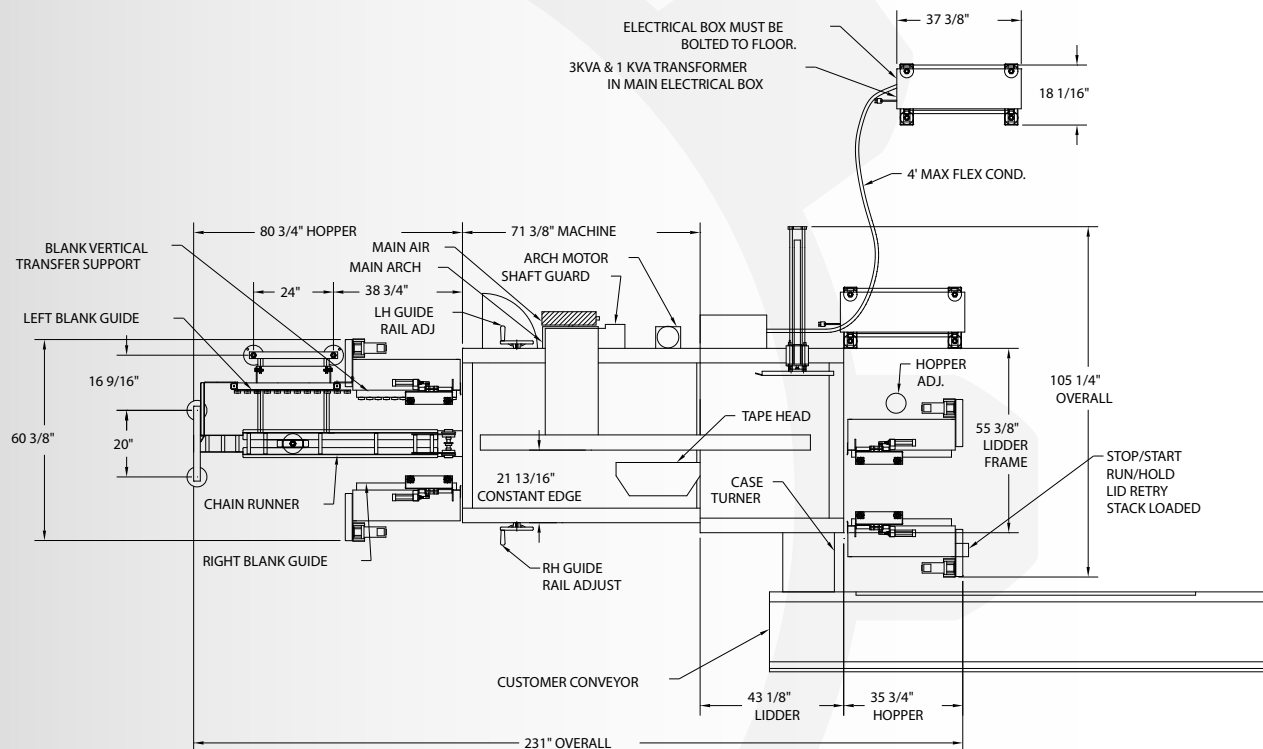

DIRECTION OF FLOW

MARQ'S
New Innovations
Info@marq.net • 1-800-998-4301

OWNERSHIP - PROPRIETARY DATA LEGEND

THIS DOCUMENT AND THE INFORMATION CONTAINED THEREIN IS THE PROPERTY OF MARQ PACKAGING SYSTEMS, INC. RECIPIENT AGREES NOT TO USE, REPRODUCE, OR TRANSMIT THIS INFORMATION TO ANY OTHER PERSON IN WHOLE OR IN PART FOR ANY PURPOSE. WHATSOEVER, WITHOUT THE EXPRESS AUTHORIZATION OF MARQ PACKAGING SYSTEMS, INC. RECIPIENT ALSO AGREES NOT TO REPRODUCE OR TRANSMIT THIS INFORMATION TO ANY OTHER PERSON IN WHOLE OR IN PART FOR ANY PURPOSE. MARQ PACKAGING SYSTEMS, INC. AND TO PROMPTLY RETURN THIS DOCUMENT TO MARQ PACKAGING SYSTEMS, INC. UPON THE RECEIPT OF A WRITTEN REQUEST THEREFOR.

HPPE-NS-Lidder