



HPB

Bliss Former

- Frame is 3/16" steel construction
- Easy tape roll to replacement
- Designed for 24/7 operation
- Erects and bottom-seals a wide range of case sizes
- Easy adjustable
- Hand crank or motorized adjustments
- Right-hand or left-hand controls are available

MARQ
PACKAGING SYSTEMS

A division of Marquis Operating Limited Partnership

Proudly
Associated With:



MARQ Packaging offers the newest packaging innovation. The MARQ High Performance Bliss Former (HPB) was designed by our customers. We asked customers what they liked and what they didn't like about traditional bliss formers. Our engineers used this information as a stepping stone for our HPB.

The HPB was built with simplicity in mind. It features a top loading hopper (for the bliss cases), and two smaller magazines for the side panels. It uses a servo driven mandrel that has a vacuum cup on each side, for a precise pick up of the two side panels.

As the case is shuttled down from the top hopper, glue is applied as it enters the forming section. The mandrel picks up the side panels, before being pushed forward to form and discharge the case. This entire process, from start to finish, happens in a matter of seconds. This simplified process is one of the many reasons why the HPB can run 24/7 in some of the harshest operating enviroments.

Talk to a MARQ representative to see how we can streamline your packaging process.

FOOTPRINT

Standard Features

- Wiring practices conform to NFPA standards
- Operator friendly design
- Quick changeover
- Fully guarded
- Continuous feed hopper
- UL508A listed electrical panels

Operational Requirements



TOP VIEW

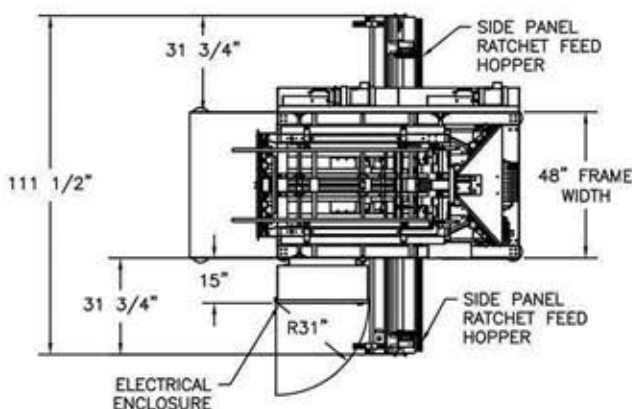

SIDE VIEW

